

MILLER precast concrete

Product Catalog

Septic Tanks

We deliver when you need it. On your schedule, not ours!

Steve Koons, owner

Cell 610-496-0483

Jared Koch, operations manager

610-594-1016

www.MillerPrecastConcrete.com

Septic Tanks

Precast Septic Tank 500 gallon capacity – rectangular	2
Precast Holding Tank - 750 gallon capacity	3
Precast 750 gallon Pump Tank with Pump	4
Precast 1 Compartment Septic Tank 1,000 gallon capacity	5
Precast 2 Compartment Septic Tank 1,000 gallon capacity	6
Precast 2 Compartment Septic Tank 1,250 gallon capacity	7
Precast 2 Compartment Septic Tank 1,500 gallon capacity	8
Precast Septic Tank Two Piece 2,000 gallon capacity	9
Precast 2 Compartment Septic Tank 2,000 gallon capacity	10
Precast Holding Tank 2,500 gallon capacity	11
Precast Holding Tank 3,000 gallon capacity	12
4,000 Gallon Septic Tank Battery with 2,000 gallon pump tank	13
Distribution Boxes with Plastic Pipe Seals	14
Distribution Box 14 Way	15
Free Access Sand Filter 40 Square Feet w/ Alum. Hatches	16
Free Access Sand Filter 60 Square Feet w/ Alum. Hatches	17
Free Access Sand Filter 80 Square Feet w/ Alum. Hatches	18
500 GPD Aerobic Treatment Plant	19

**These are the most requested products. Other items available,
 contact us for ALL YOUR PRECAST NEEDS**

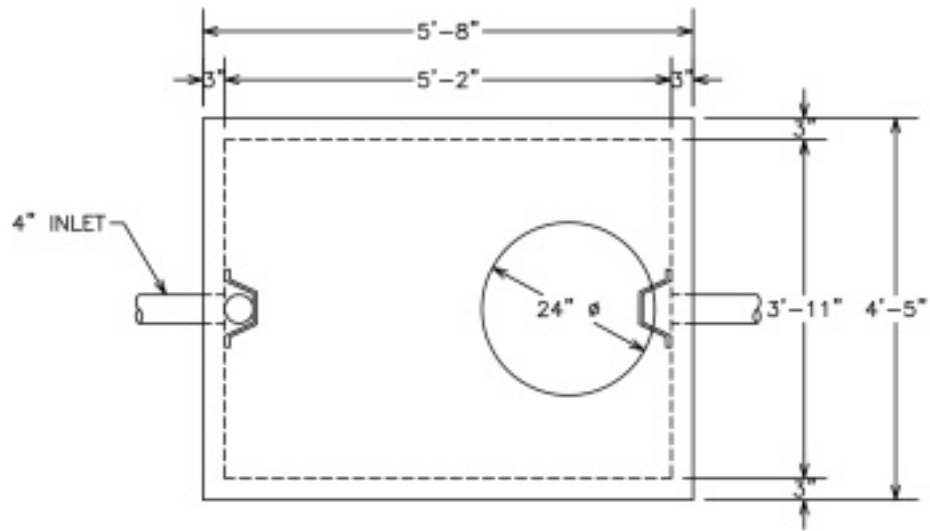

—PLAN—

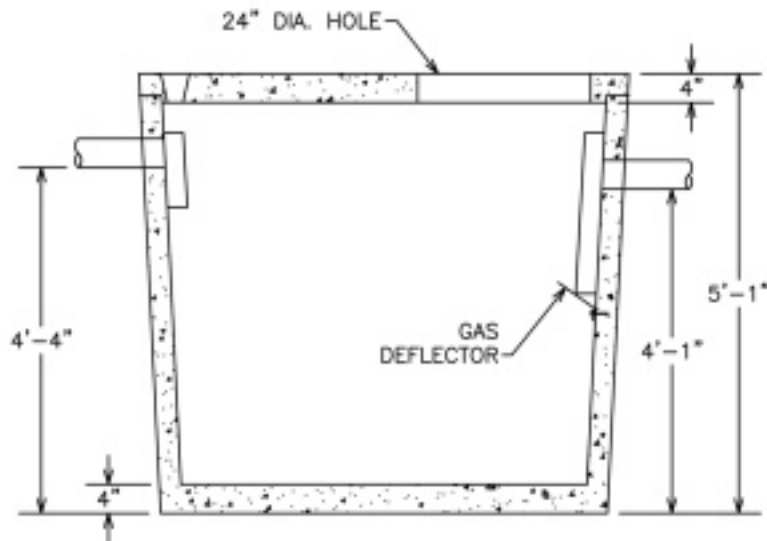

—SECTION—

500 GALLON
RECTANGULAR SEPTIC TANK

DWG. ST5-STGD

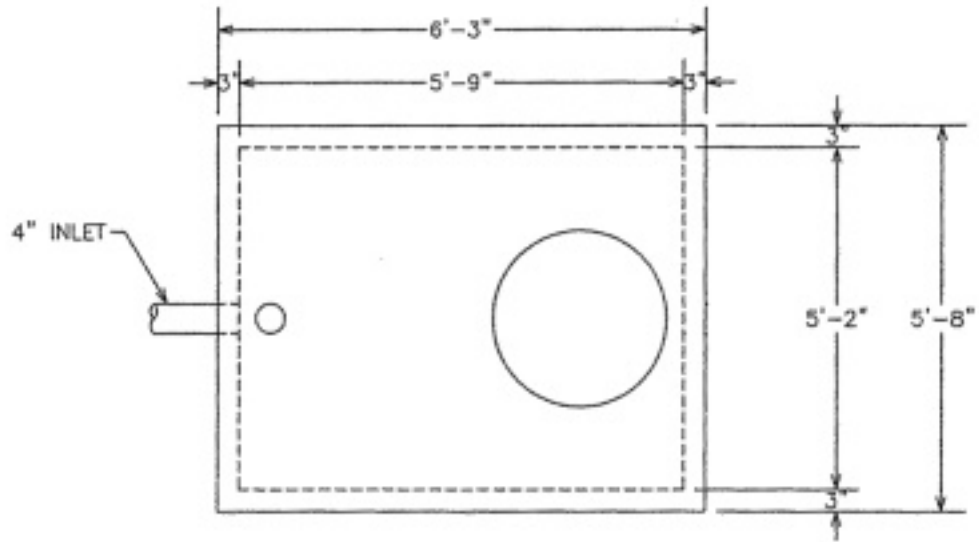

-PLAN-

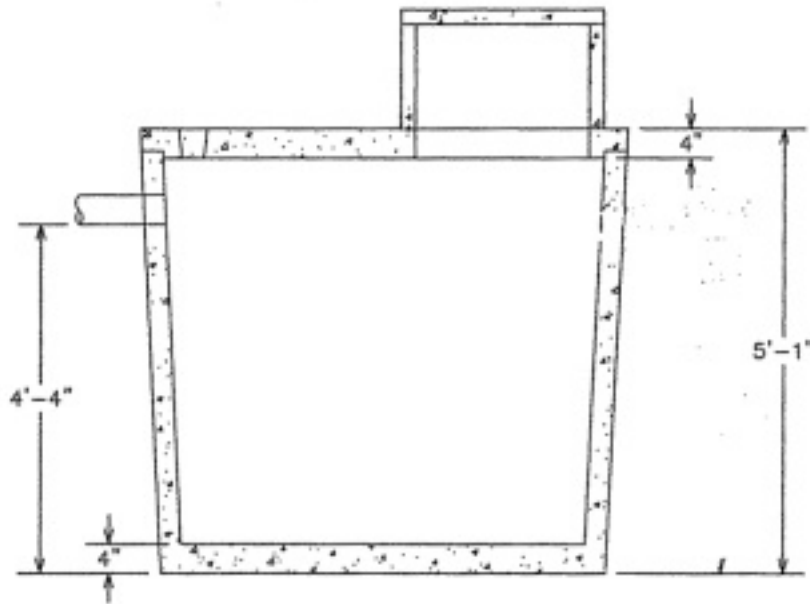

-SECTION-

750 GALLON

TANK

ST-750R

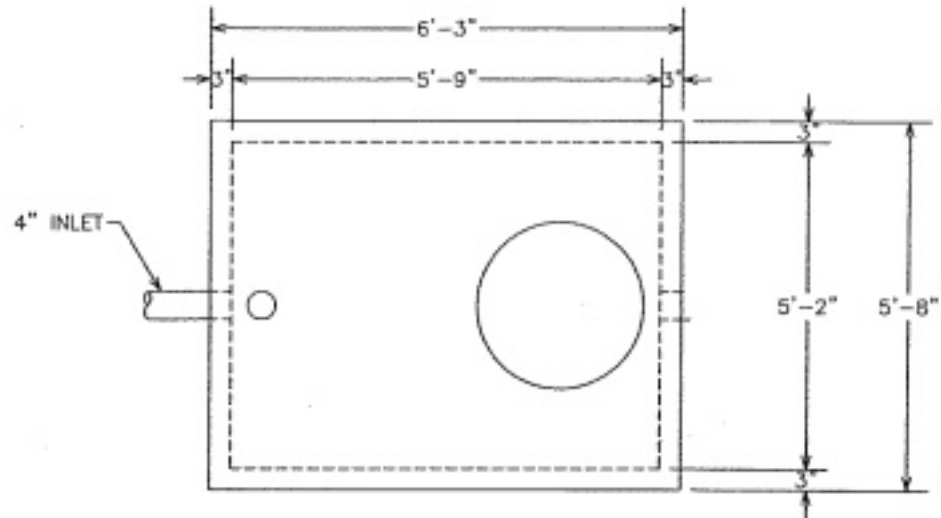

-PLAN-

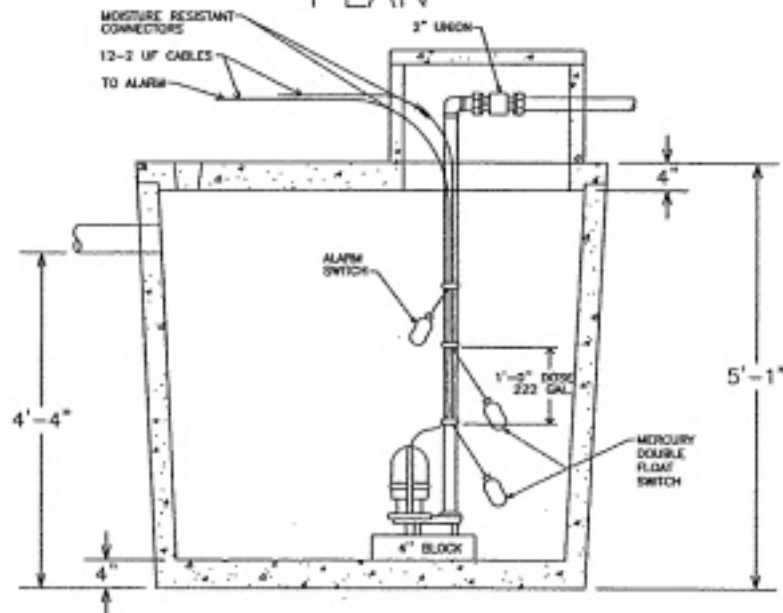

-SECTION-

750 GALLON PUMP TANK
WITH PUMP

PT-750R

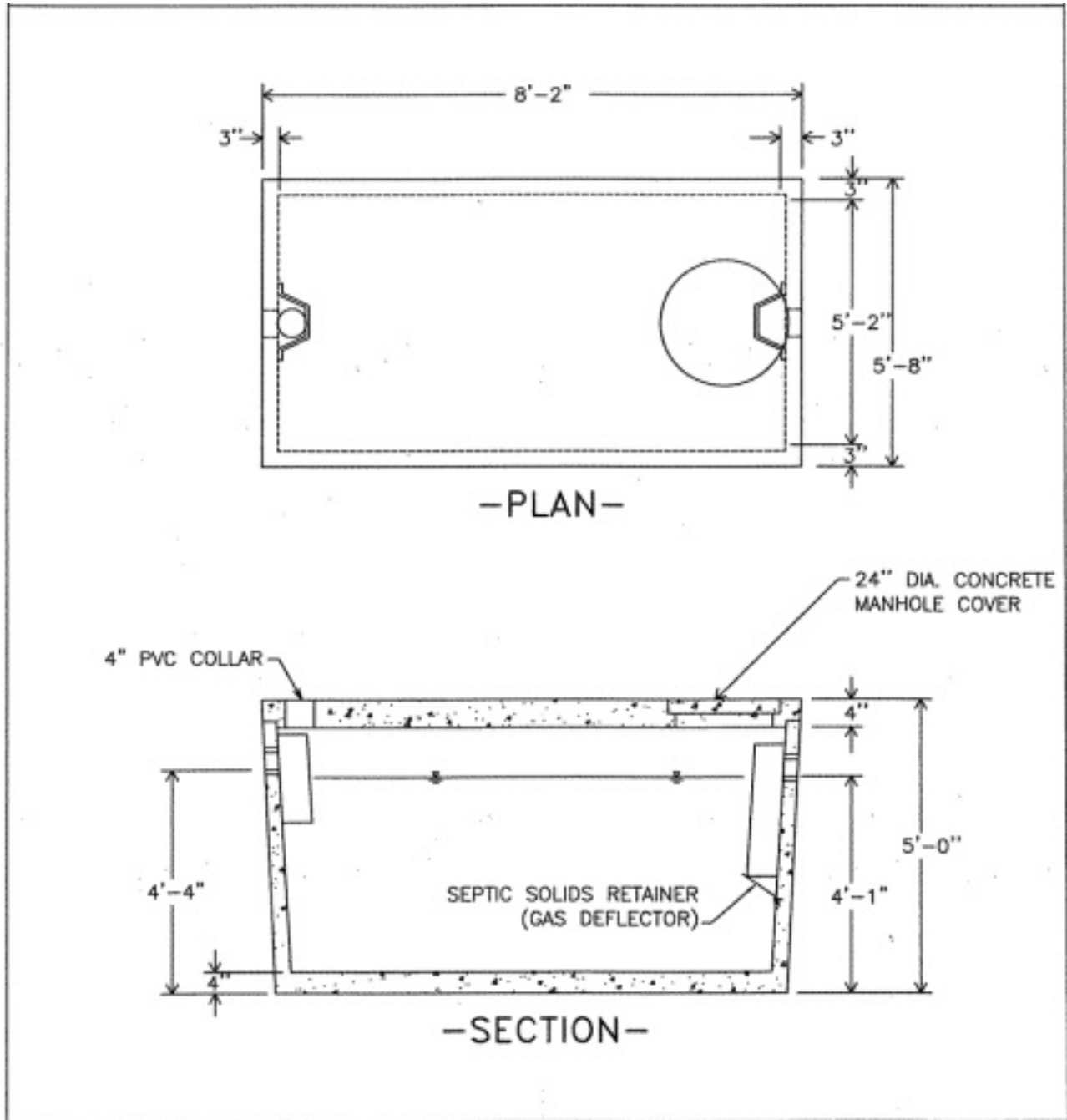

Precast 1-Compartment Septic Tank
1,000 Gallon Capacity

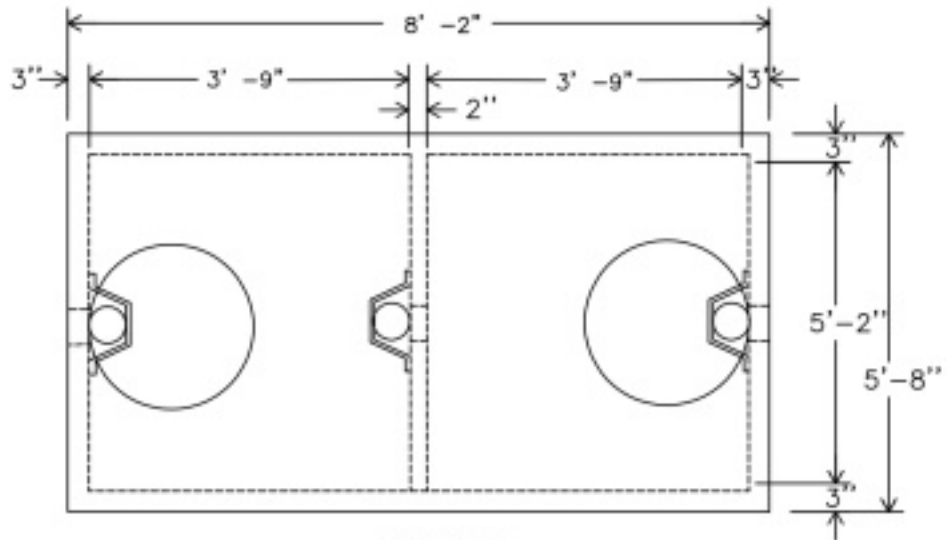

-PLAN-

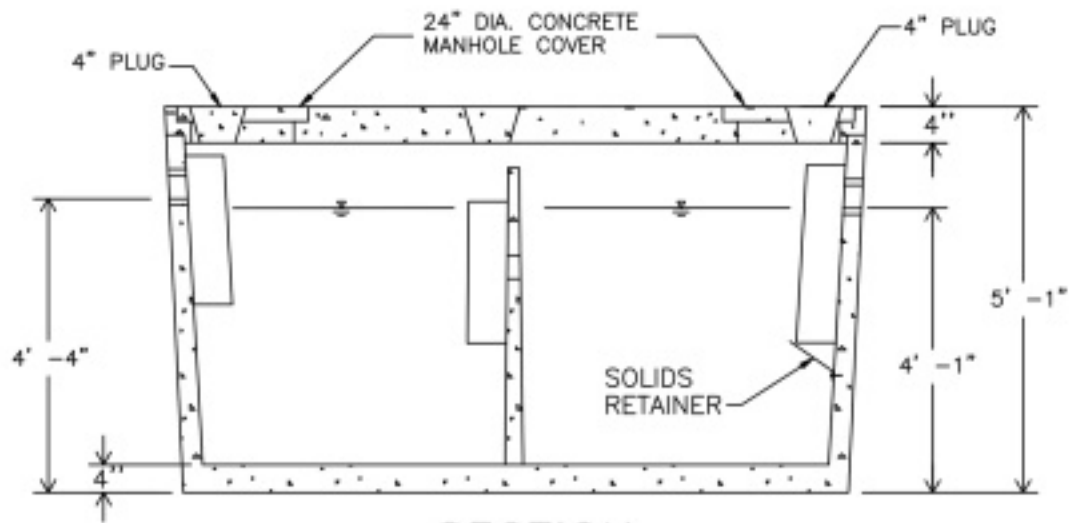

-SECTION-

PRECAST 2 COMPARTMENT SEPTIC TANK
1000 GALLON CAPACITY

DWG. ST 10-2

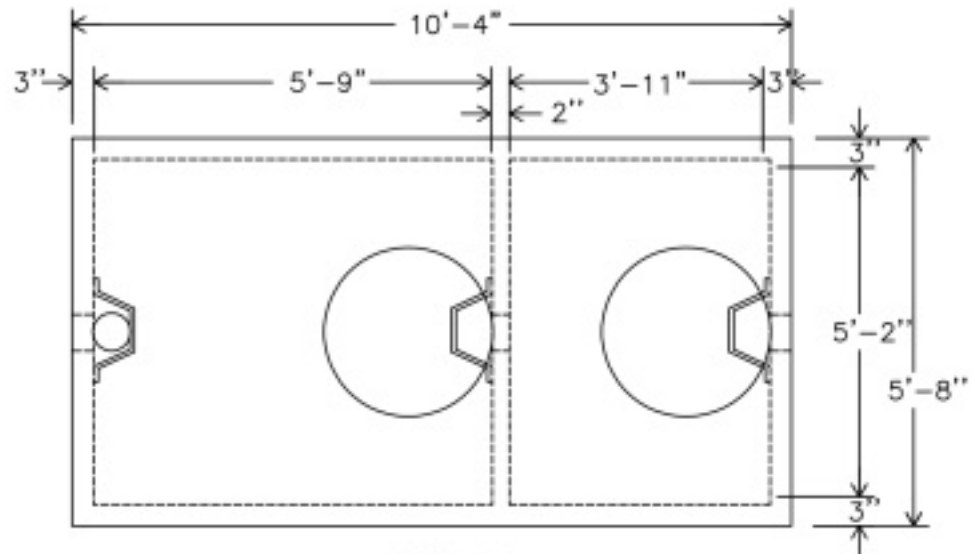

-PLAN-

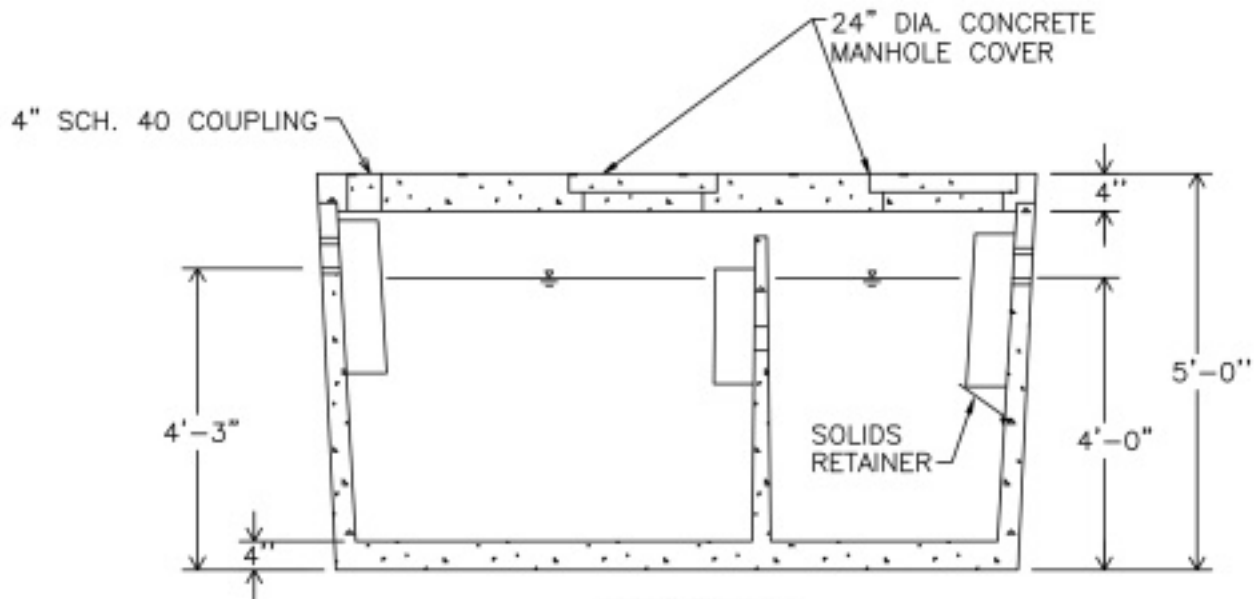

-SECTION-

PRECAST 2 COMPARTMENT SEPTIC TANK
1250 GALLON CAPACITY

DWG. ST-12-2

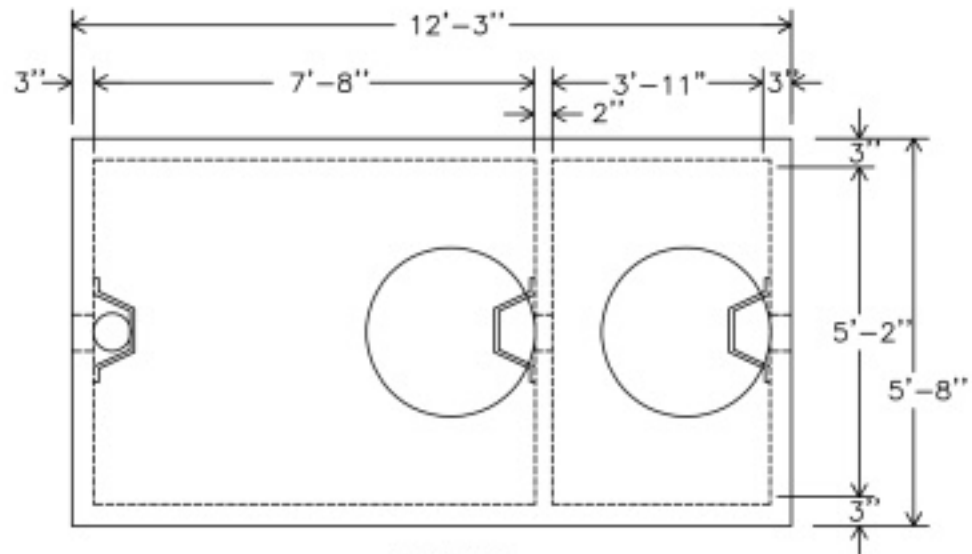

-PLAN-

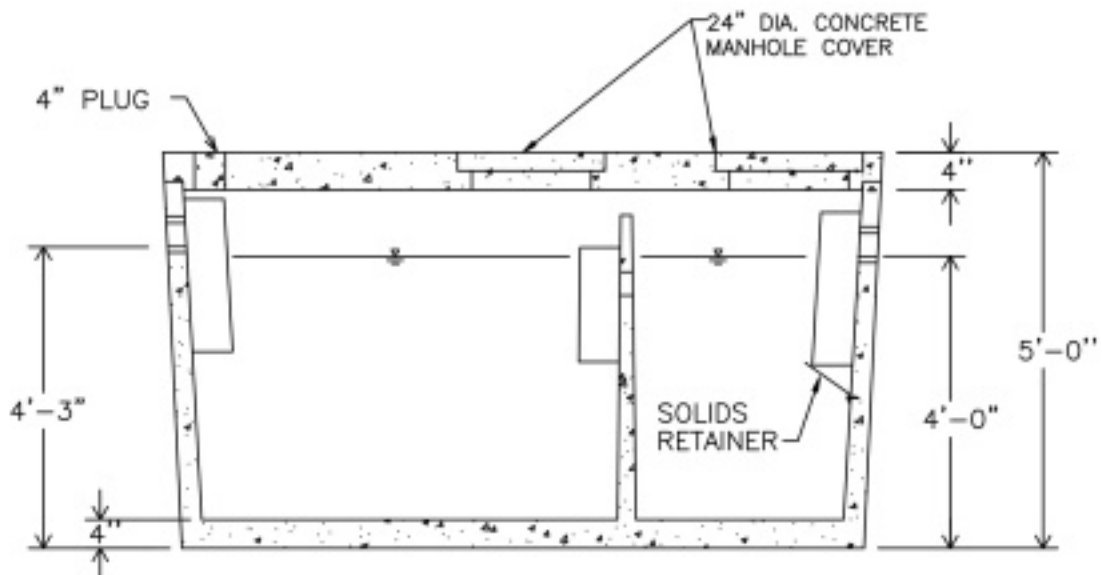

-SECTION-

PRECAST 2 COMPARTMENT SEPTIC TANK
1500 GALLON CAPACITY

DWG. ST-15-2

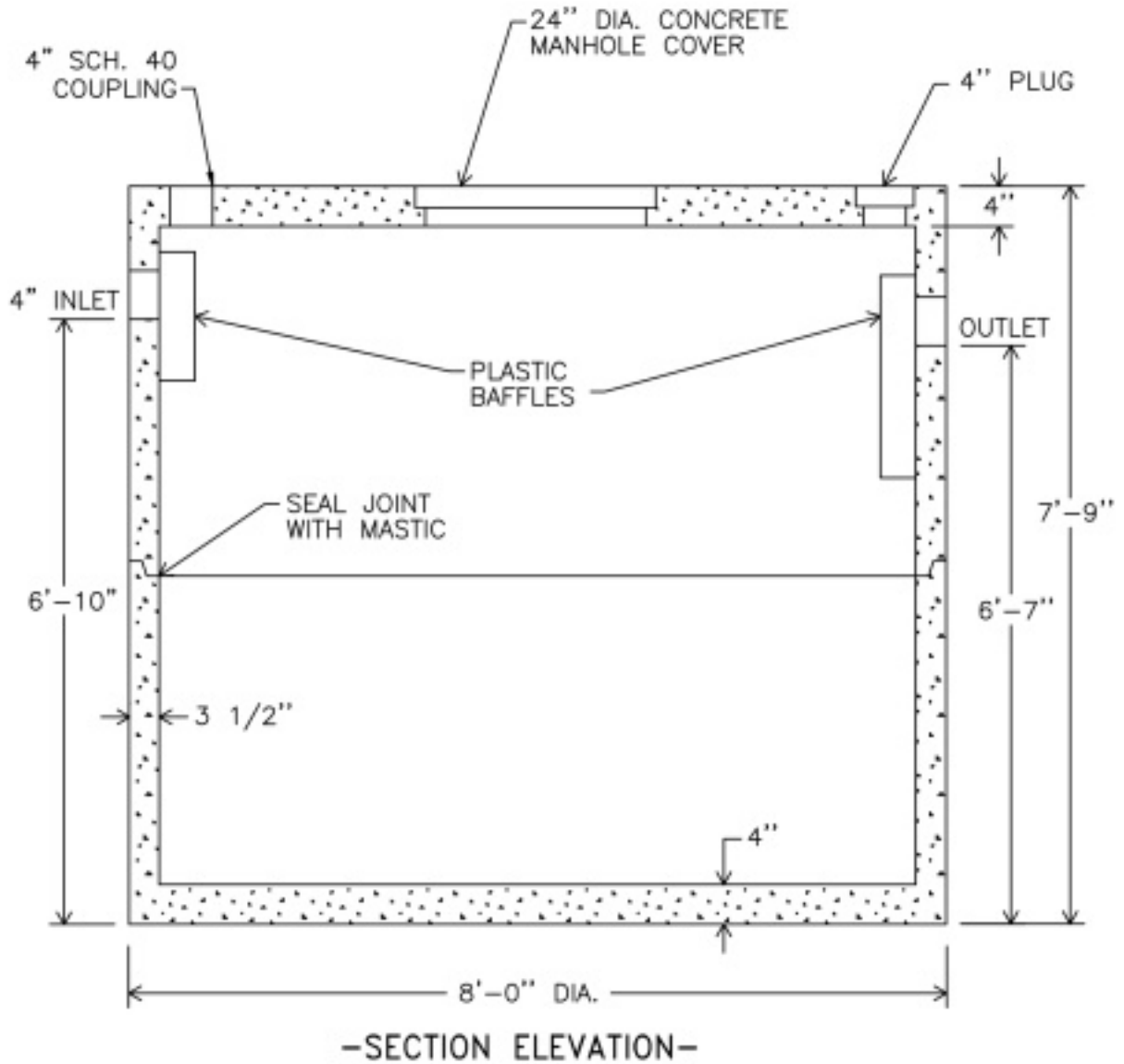

PRECAST SEPTIC TANK 2000 GALLON CAPACITY

DWG. ST-20

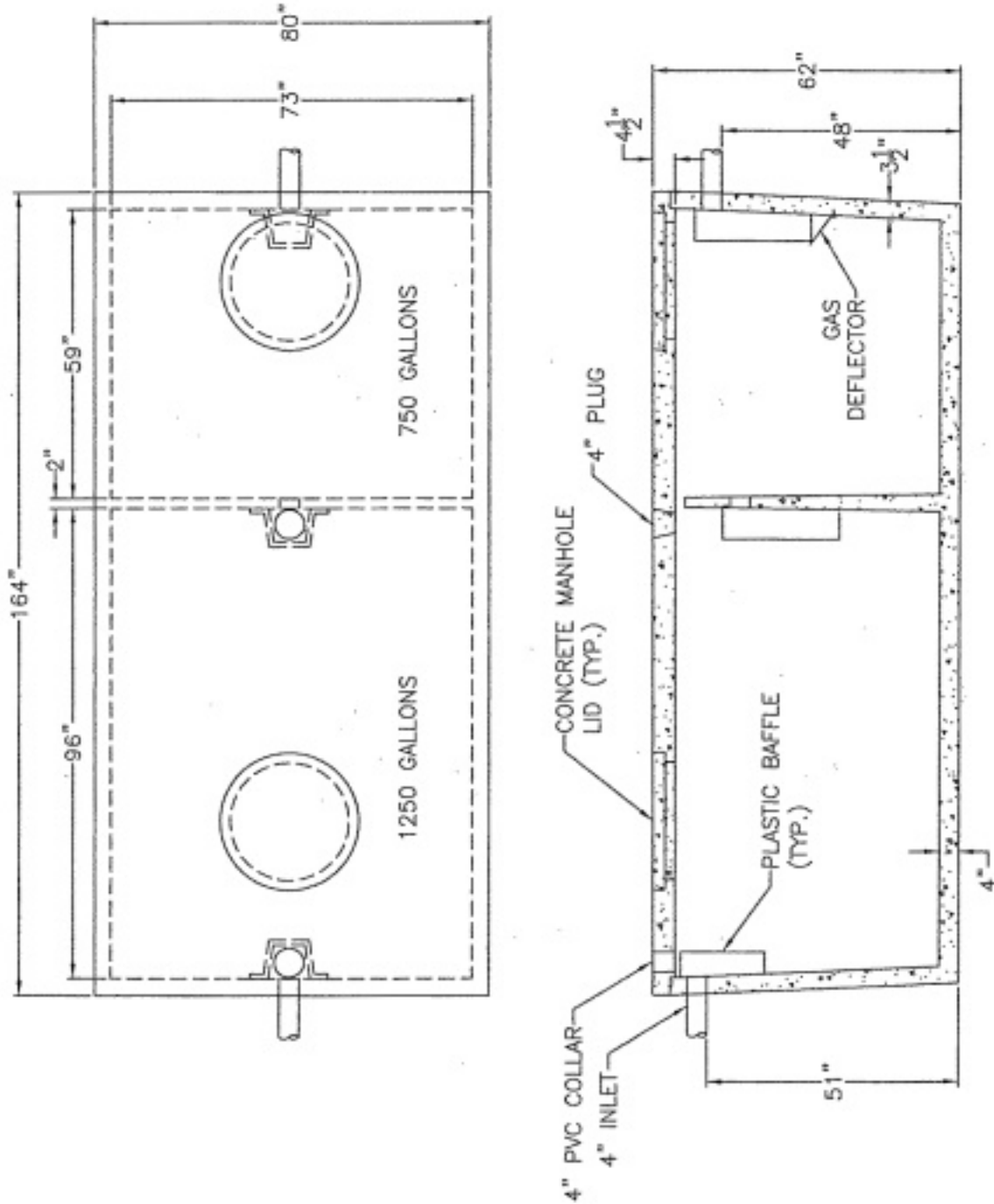

PRECAST 2 COMPARTMENT SEPTIC TANK
2000 GALLON CAPACITY

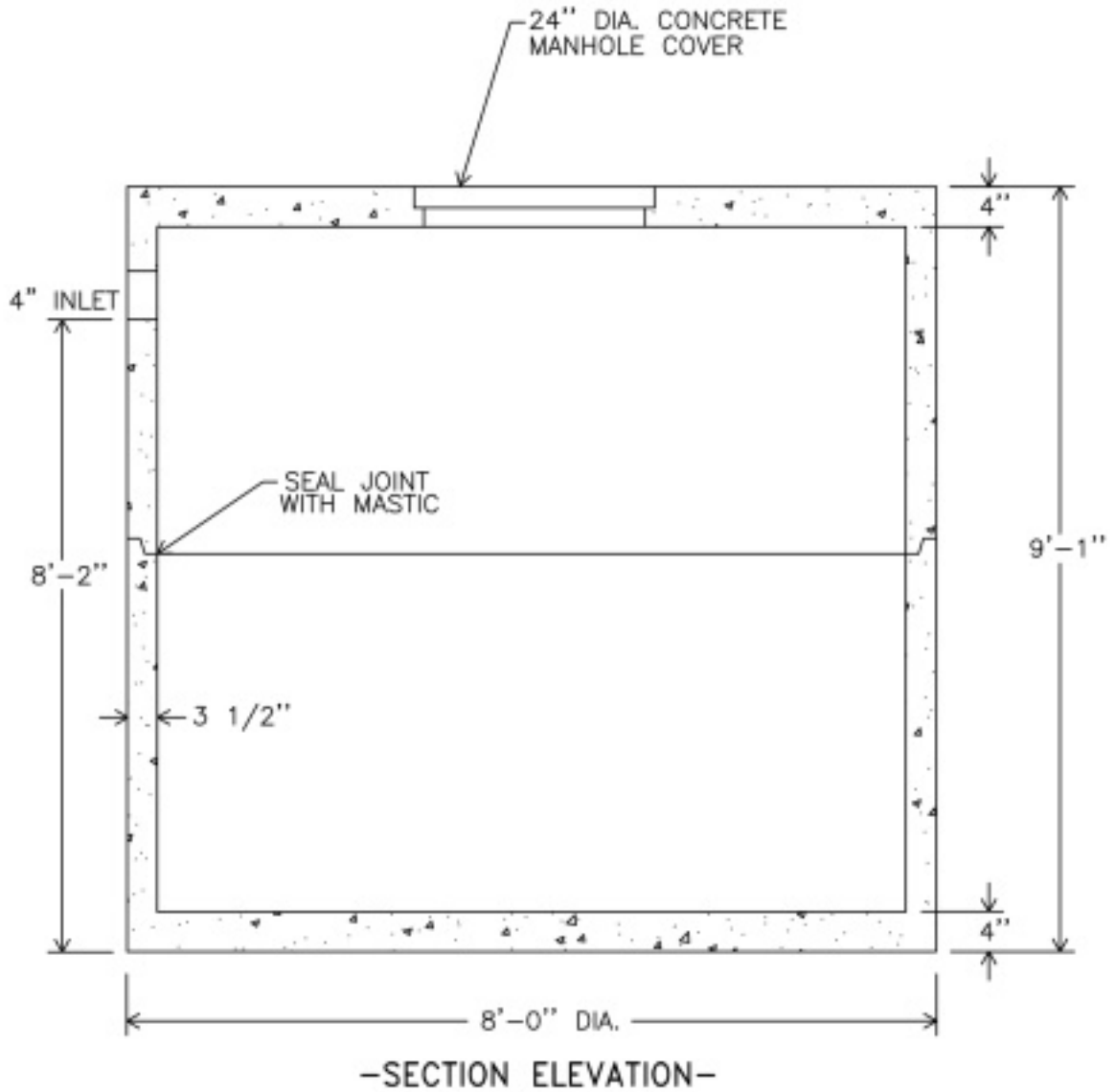

PRECAST HOLDING TANK
2500 GALLON CAPACITY

DWG. ST-25

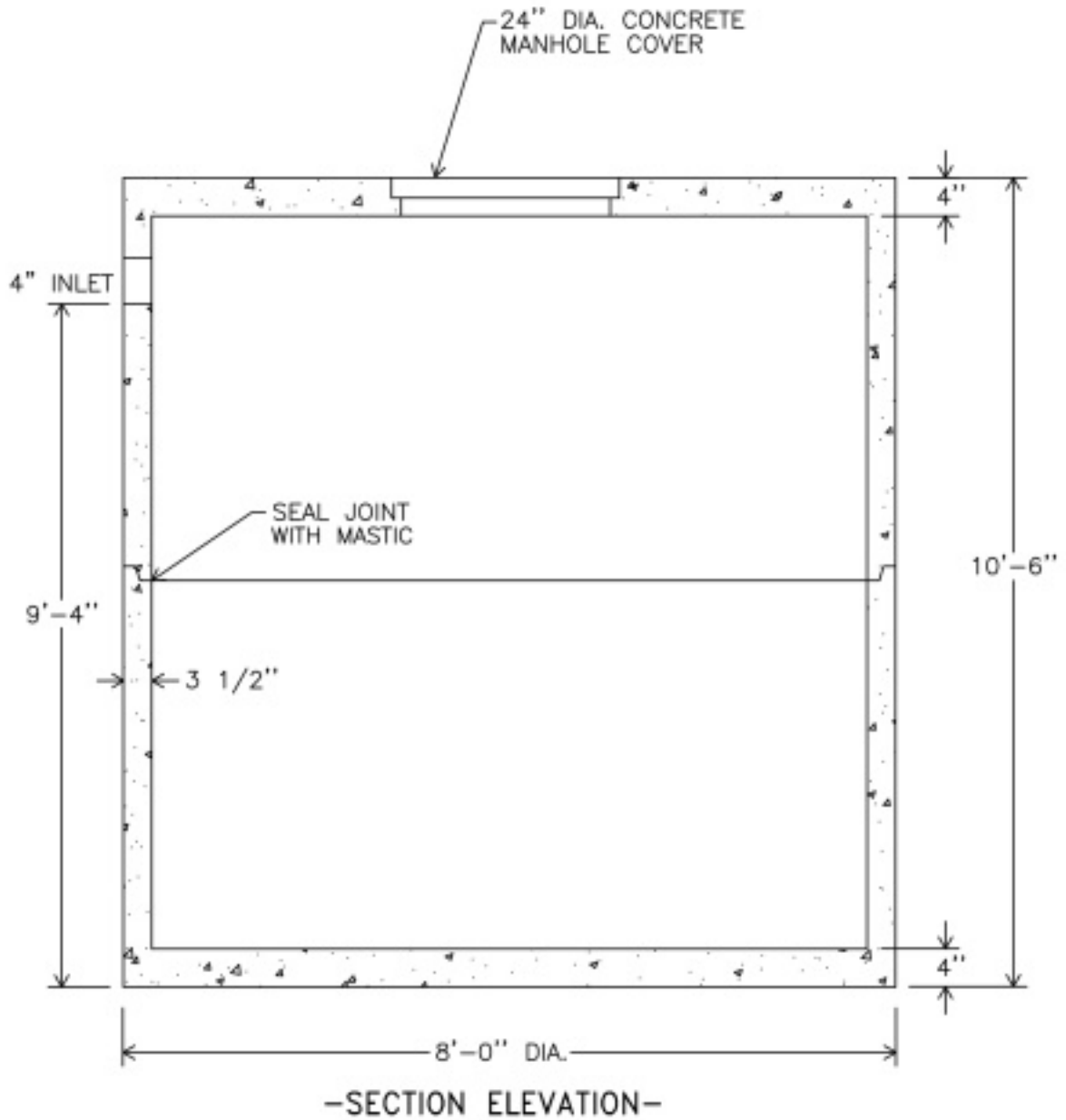

PRECAST HOLDING TANK
3000 GALLON CAPACITY

DWG. ST-30

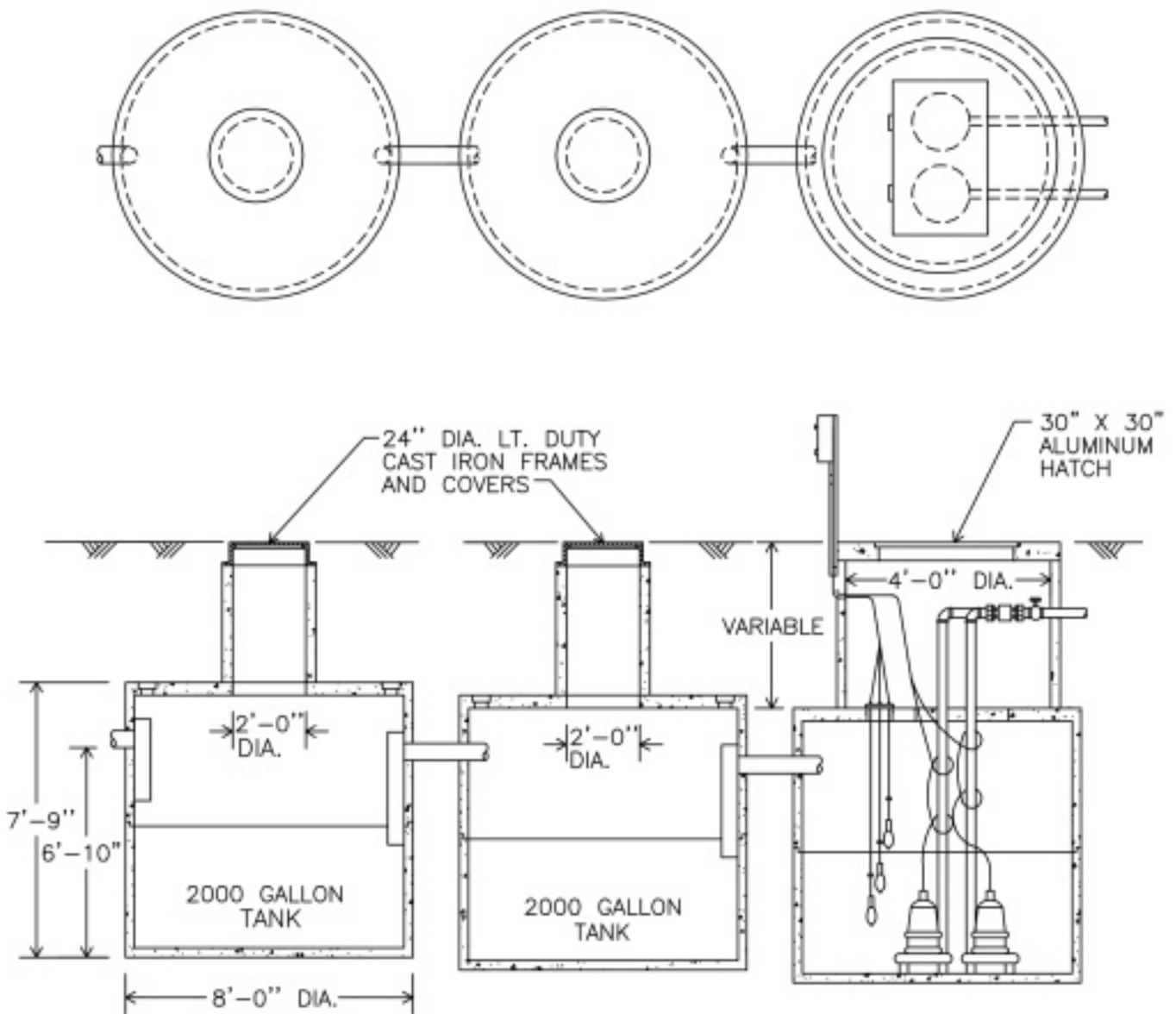

4000 GALLON SEPTIC TANK BATTERY
WITH 2000 GALLON PUMP TANK

DWG. ST-40

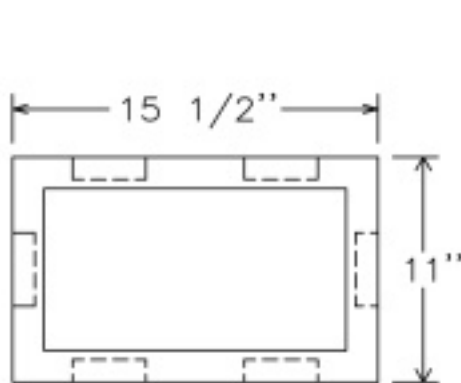

-PLAN-

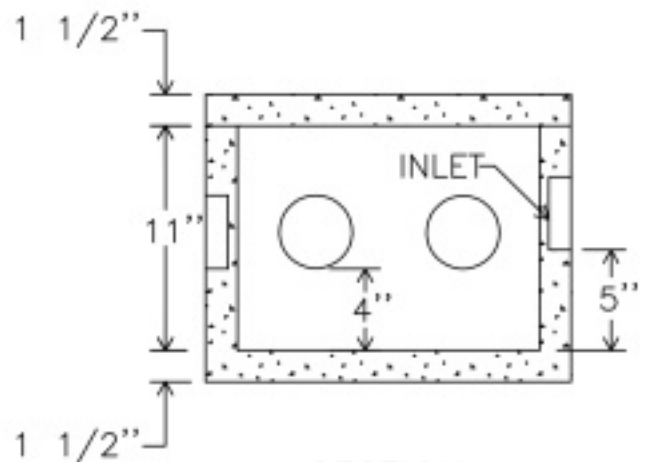

-SECTION-

5 WAY D-BOX

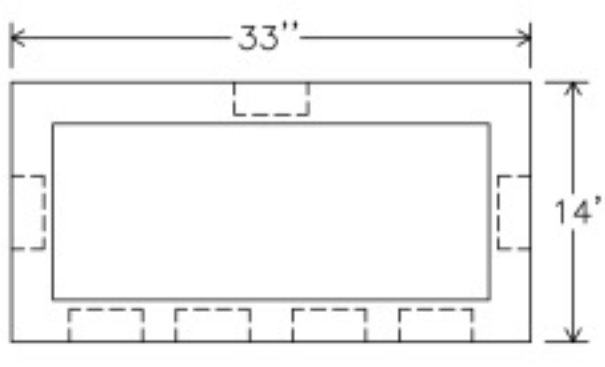

-PLAN-

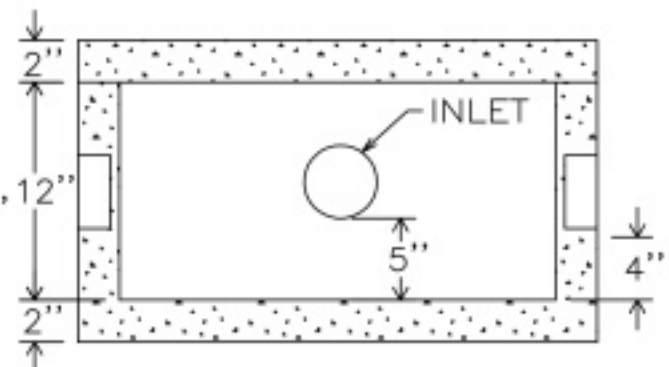

-SECTION-

7 WAY D-BOX

DISTRIBUTION BOXES
WITH PLASTIC PIPE SEALS

DWG. DB-1

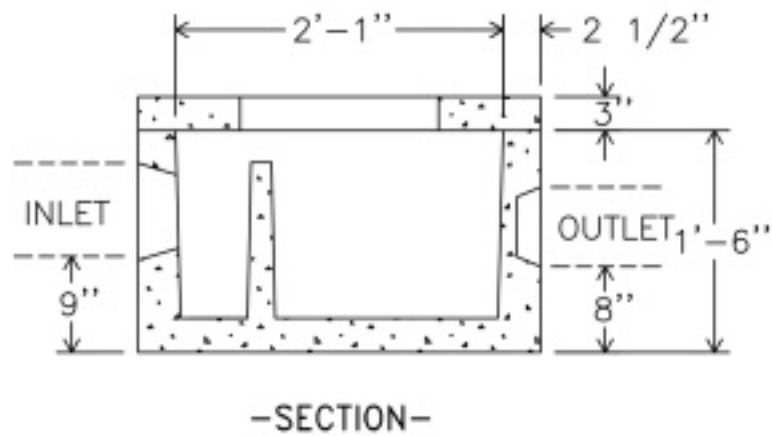
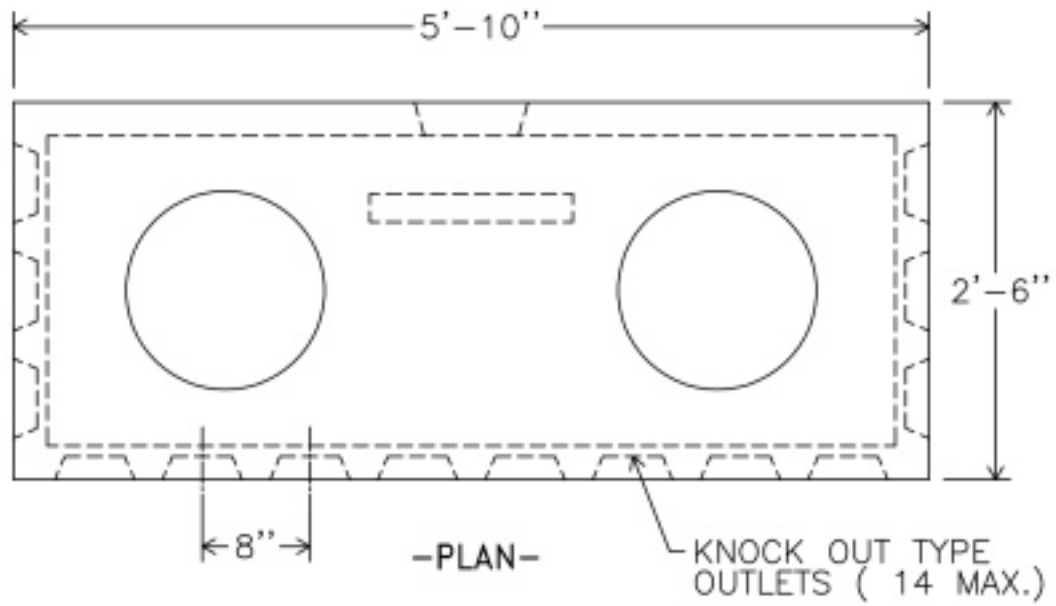

DISTRIBUTION BOX 14 WAY

DWG. DB-2

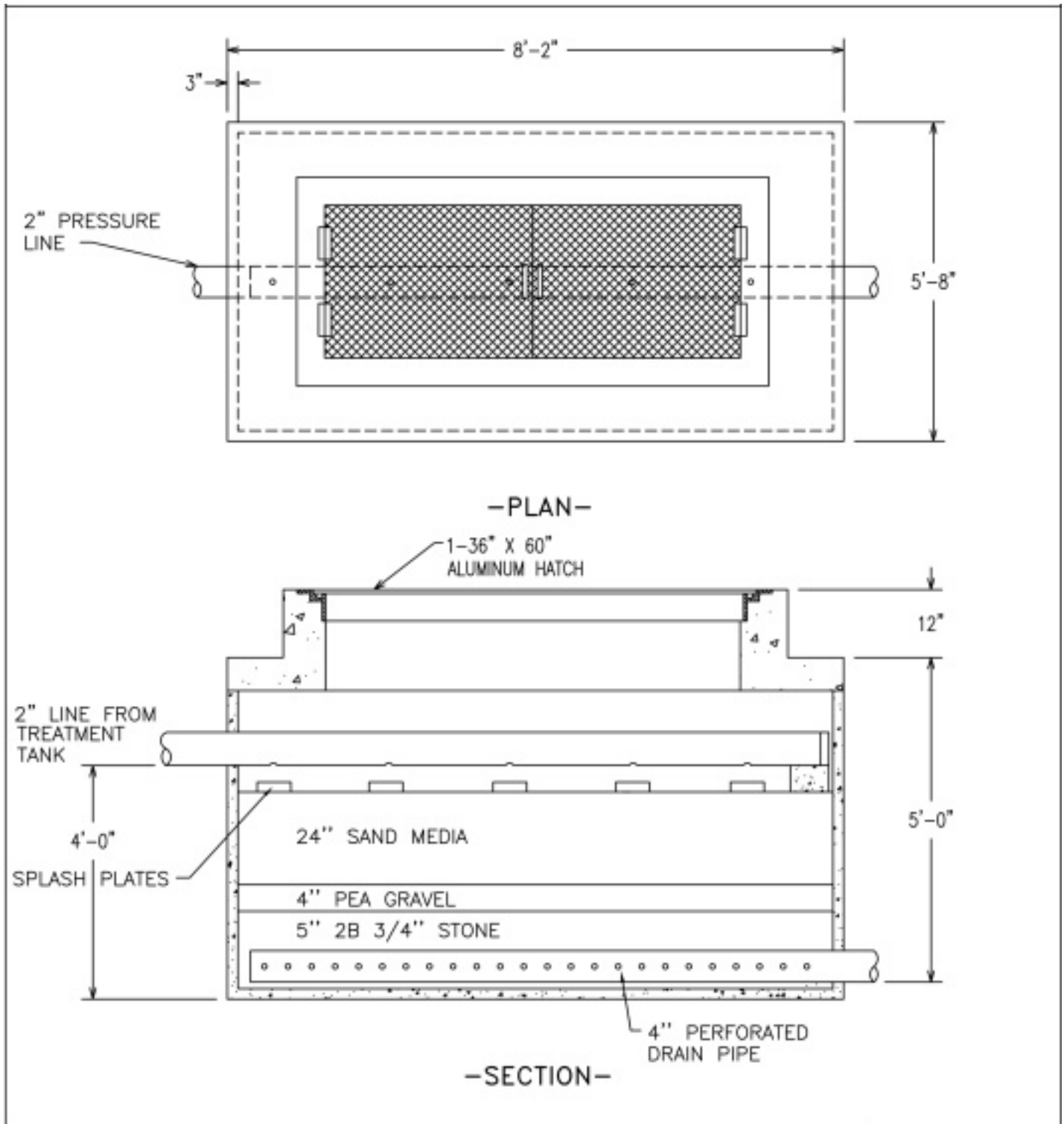

FREE ACCESS SAND FILTER
 40 SQUARE FEET W/ ALUM. ACCESS DOOR

DWG. SFT-1A

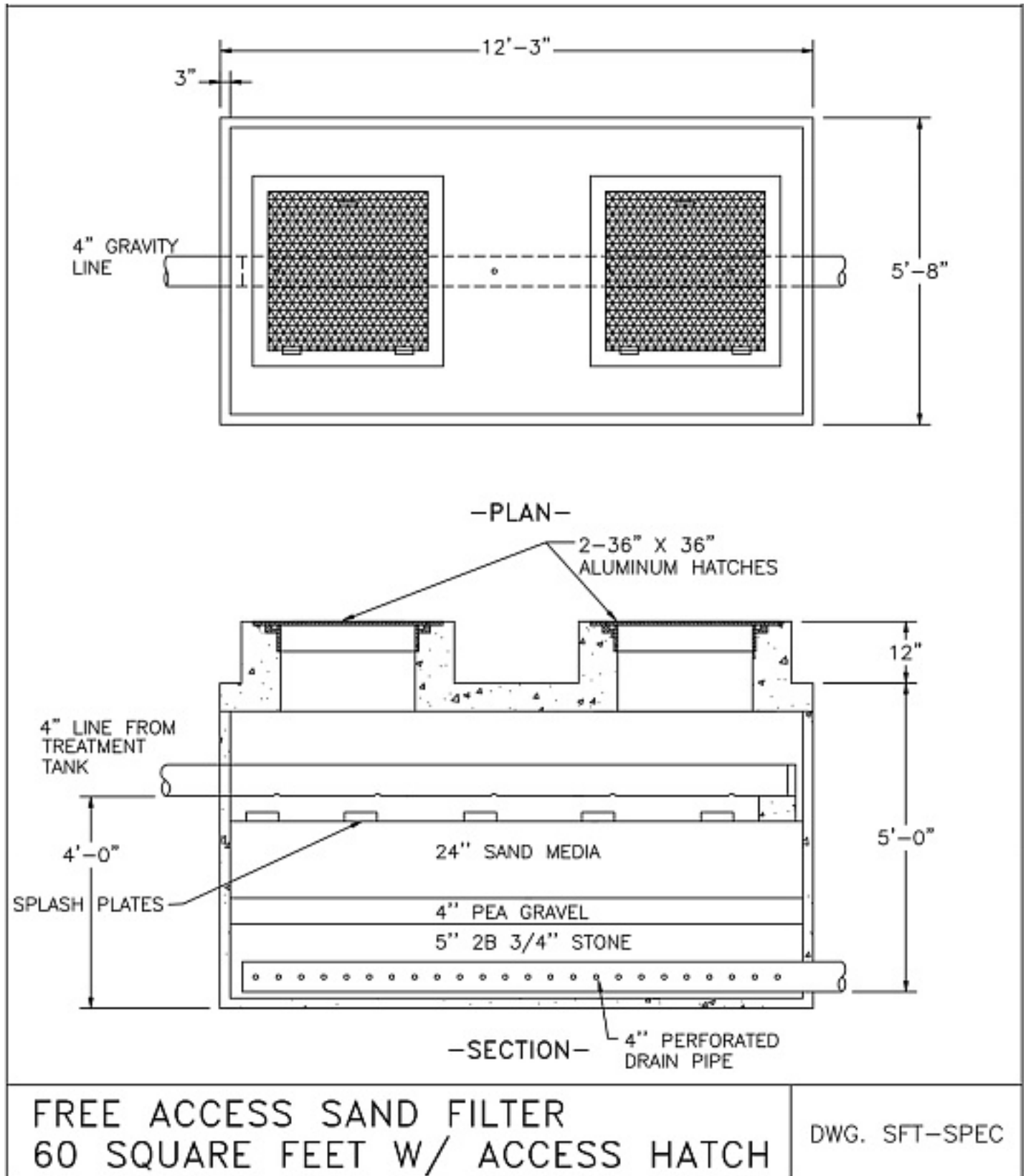

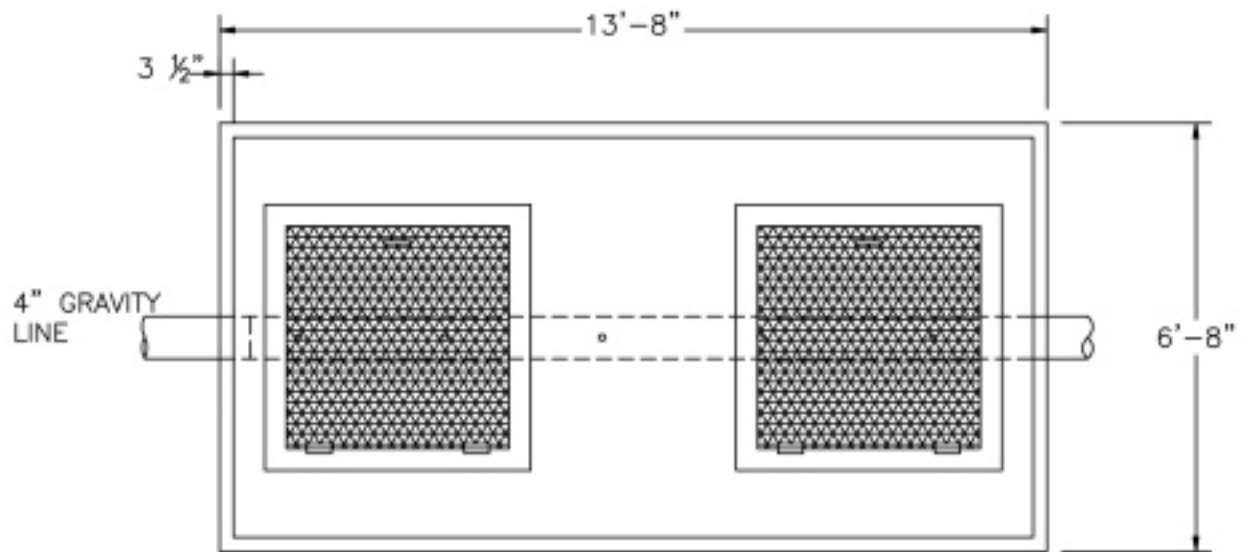

-PLAN-

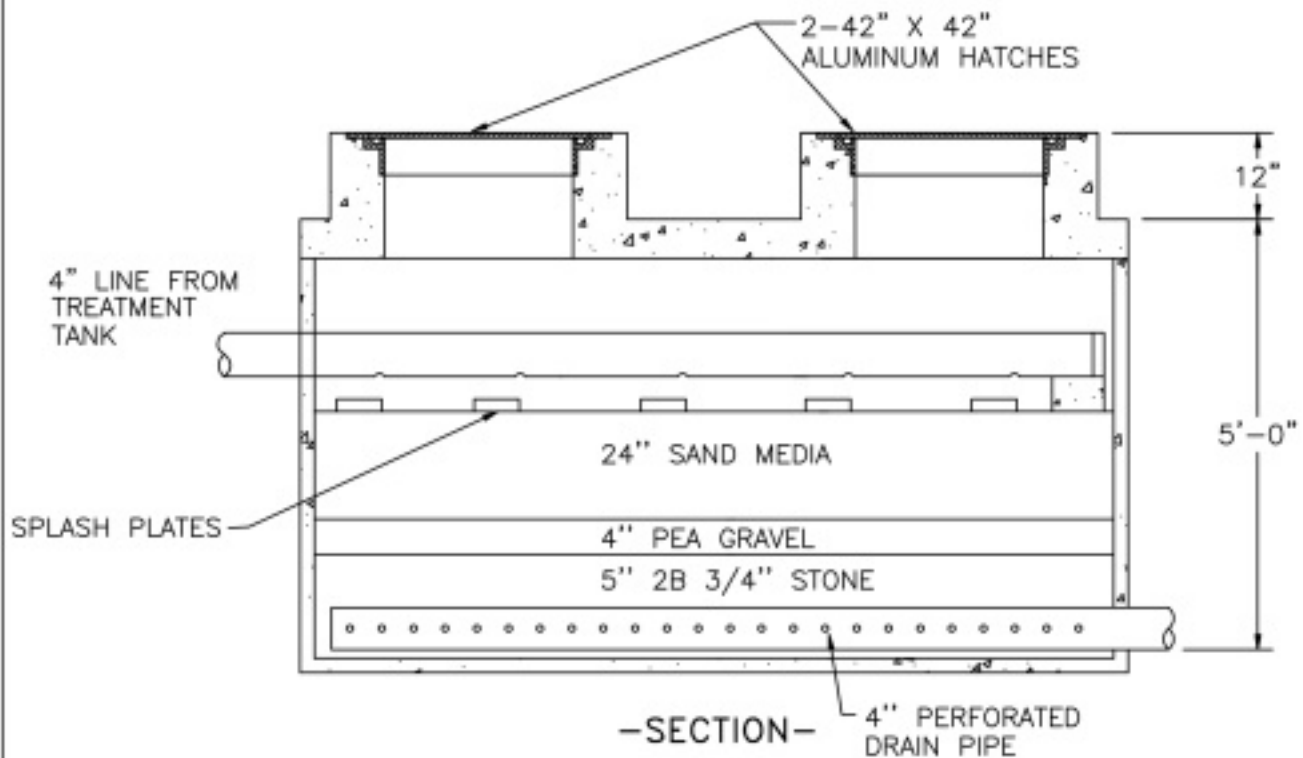

-SECTION-

80 SQUARE FEET FREE ACCESS SAND
FILTER W/ ALUM. ACCESS DOORS

DWG. SFT-80

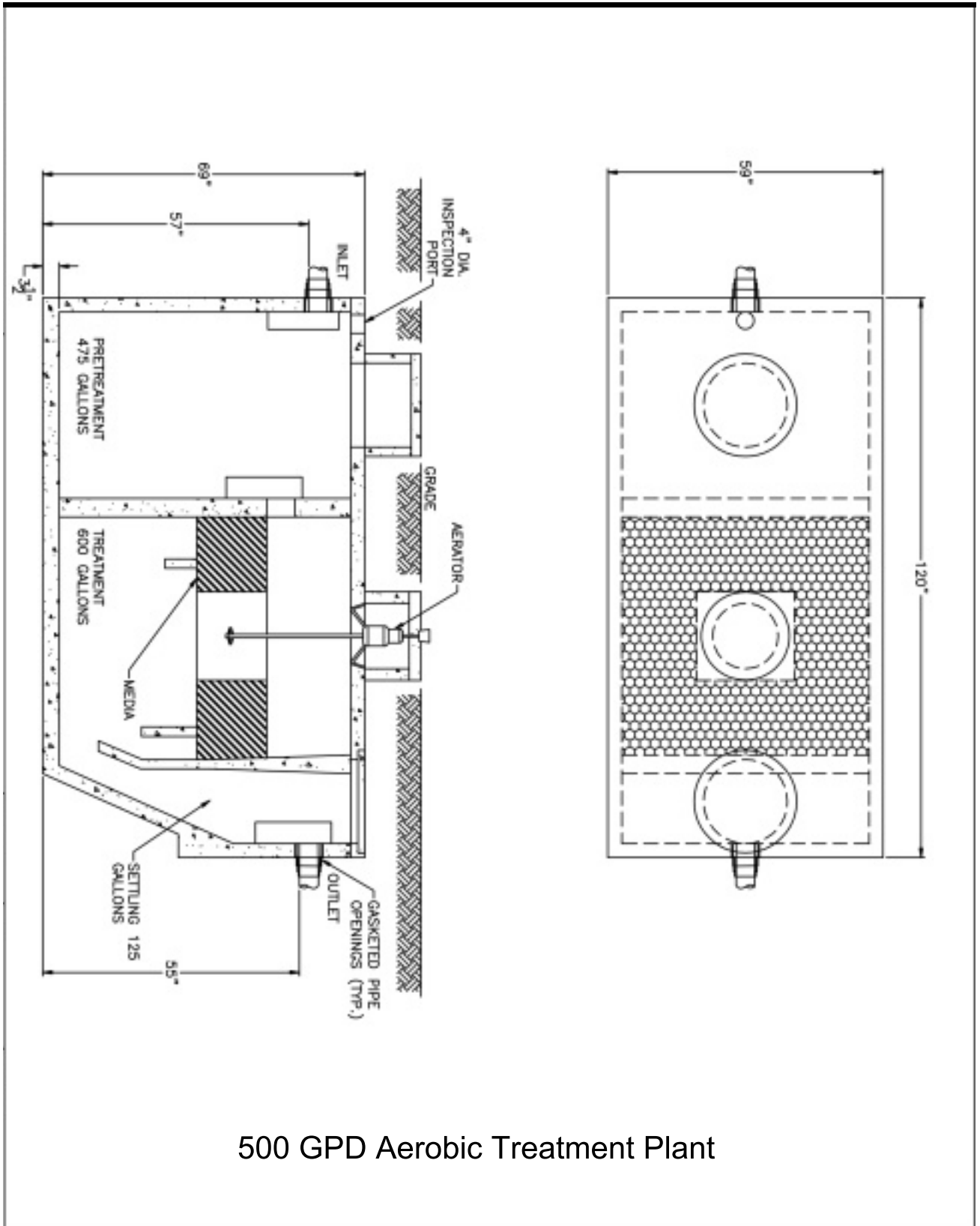

500 GPD Aerobic Treatment Plant